

The Run Daybed offers multiple configurations to adapt to your different needs. You can choose to use one, two or all three cushions, with or without the bolster pillow.

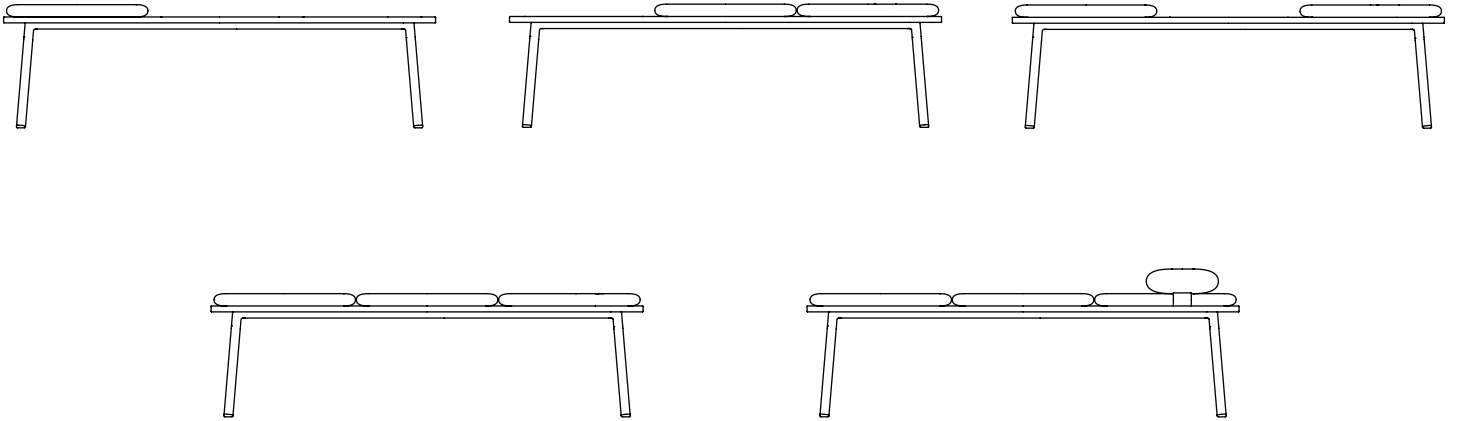

Each cushion comes with a dowel rod to help keep the cushion in place. Slip the loops on the underside of the cushion through the center gap in the Run platform and slide the rod through both loops to secure.

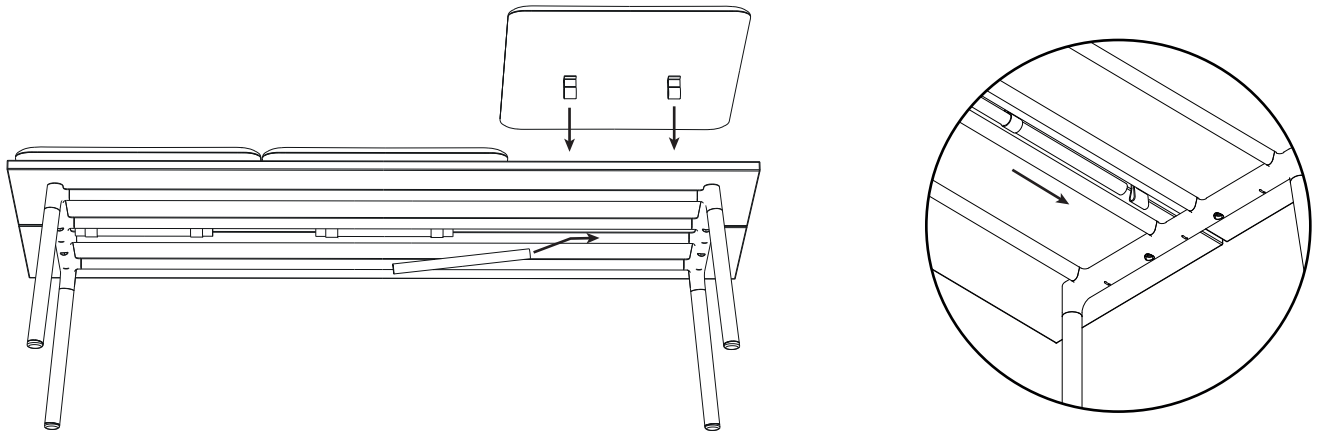

Wrap the straps of the bolster pillow around and secure underneath the cushion using the Velcro .

